

Atosa MGF8450GR Chef Base 215 L (2 Drawer) – Under Broiler Counter



2 Drawer Refrigerated Chef Base, with 215 litre capacity, constructed of stainless steel interior and exterior, with automatic defrost and standard castors with front brakes.

- ✔ High Grade Stainless Construction Interior
- ✔ High Grade Stainless Construction Exterior
- ✔ Easy to clean black plastic drawer handles
- ✔ Comes complete with gastronorm pans
- ✔ Side Mounted Heavy Duty Compressor Unit
- ✔ Magnetic door gaskets
- ✔ Pre-installed castors
- ✔ Climate Class 5 product

SPECIFICATIONS

Summary		Power and Performance	
Brand	Atosa	Voltage (V/HZ/PH)	220/50/1
Model	MGF8450GR	Power (Watts)	300
Gastronorm Pan Capacity	2 x 1/1 & 3 x 1/6 per drawer (2 drawers)	Electrical Current (Amps)	1.7
Material External	Stainless Steel	kWh/annum	518
Material Internal	Stainless Steel		

Key Specifications		Weights and Dimensions	
Gross Capacity (Litre)	215	Exterior Dimension (WxDxH) mm	1230 x 814 x 675
Nett Capacity (Litre)	80	Interior Dimension (WxDxH) mm	922 x 650 x 424
Energy Efficiency Class	B	Packing Dimension (WxDxH) mm	1285 x 885 x 735
Climate Class	5	Net Weight (kg)	100
Defrost Method	Air Defrost	Gross Weight (kg)	117
Refrigerant Type / Amount	R600a / 90 g		
Cooling Method	Ventilated		
Inner Temperature (°C)	+2°C to +8°C		
Insulation	Polyurethane		
Foaming Material	C5H10		
Castors	4 (2 Braked on front)		

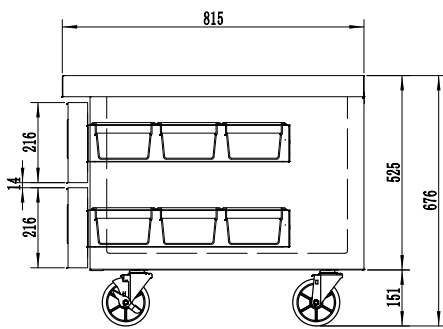
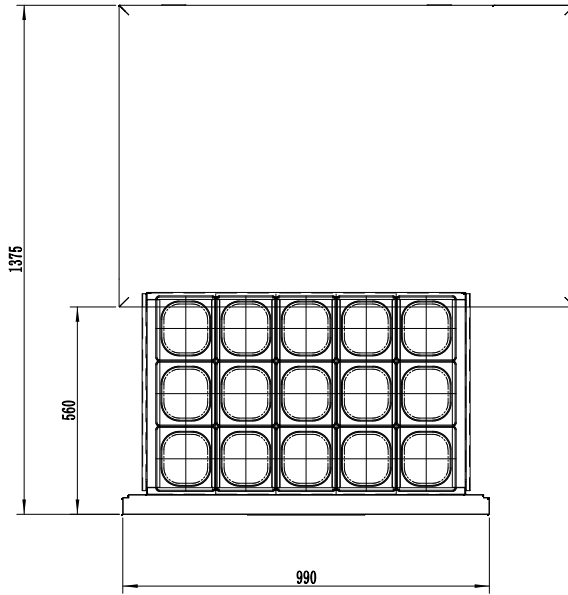

SIDE VIEW

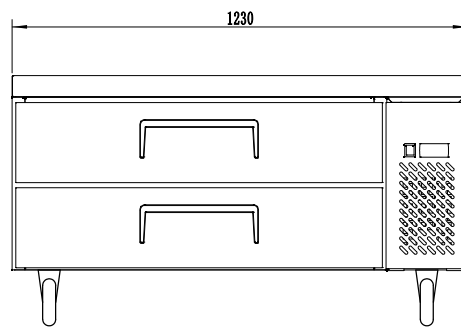

ENERGY

Atosa[®] MGF8450GR

A+++

A++

A+

A

B

C

D

E

F

G

B

518

kWh/annum

80

L

-

L

5

40°C-40%

2015/1094-IV