

Atosa MGF8451GR Chef Base 235 L (2 Drawer) – Under Broiler Counter

2 Drawer Refrigerated Chef Base, with 235 litre capacity, constructed of stainless steel interior and exterior, with automatic defrost and standard castors with front brakes.



- ✓ Side Mounted Heavy Duty Compressor Unit
- ✓ High Grade Stainless Construction Interior
- ✓ High Grade Stainless Construction Exterior
- ✓ Easy to clean black plastic drawer handles
- ✓ Comes complete with gastronorm pans
- ✓ Magnetic drawer gaskets
- ✓ Pre-installed castors
- ✓ Climate Class 5 product

SPECIFICATIONS

Summary		Power and Performance	
Brand	Atosa	Voltage (V/HZ/PH)	220/50/1
Model	MGF8451GR	Power (Watts)	300
Material External	Stainless Steel	kWh/annum	518
Material Internal	Stainless Steel	Electrical Current (Amps)	1.7
Gastronorm Pan Capacity	3 x 1/1 per drawer (2 drawers)		

Key Specifications		Weights and Dimensions	
Refrigerant Type / Amount	R600a / 90 g	Exterior Dimension (WxDxH) mm	1322 x 814 x 675
Gross Capacity (Litre)	235	Interior Dimension (WxDxH) mm	1016 x 650 x 424
Nett Capacity (Litre)	97	Packing Dimension (WxDxH) mm	1590 x 885 x 735
Climate Class	5	Net Weight (kg)	104
Energy Efficiency Class	B	Gross Weight (kg)	117
Defrost Method	Air Defrost		
Cooling Method	Ventilated		
Inner Temperature (°C)	+2°C to +8°C		
Insulation	Polyurethane		
Foaming Material	C5H10		
Castors	4 (2 Braked on front)		

PLAN VIEW
MGF8451GR

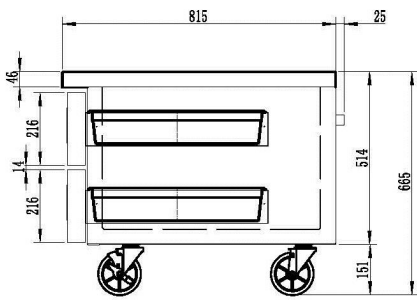
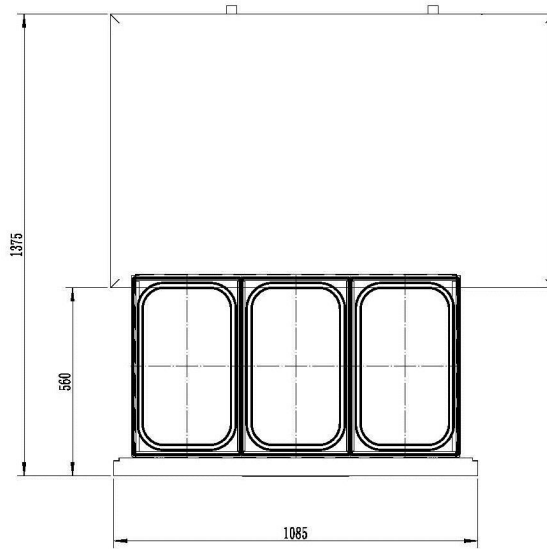

SIDE VIEW

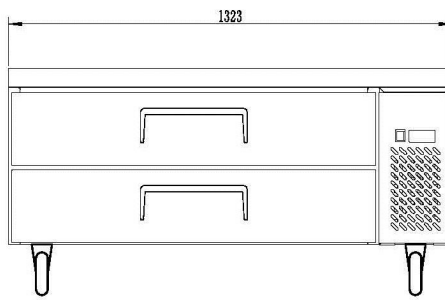

ENERGY

MGF8451GR

A+++

A++

A+

A

B

C

D

E

F

G

B

518
kWh/annum

97 L

- L

5
40°C-40%

2015/1094-IV